

Process flaps

# Gas-tight butterfly valve

in plastic and ATEX design

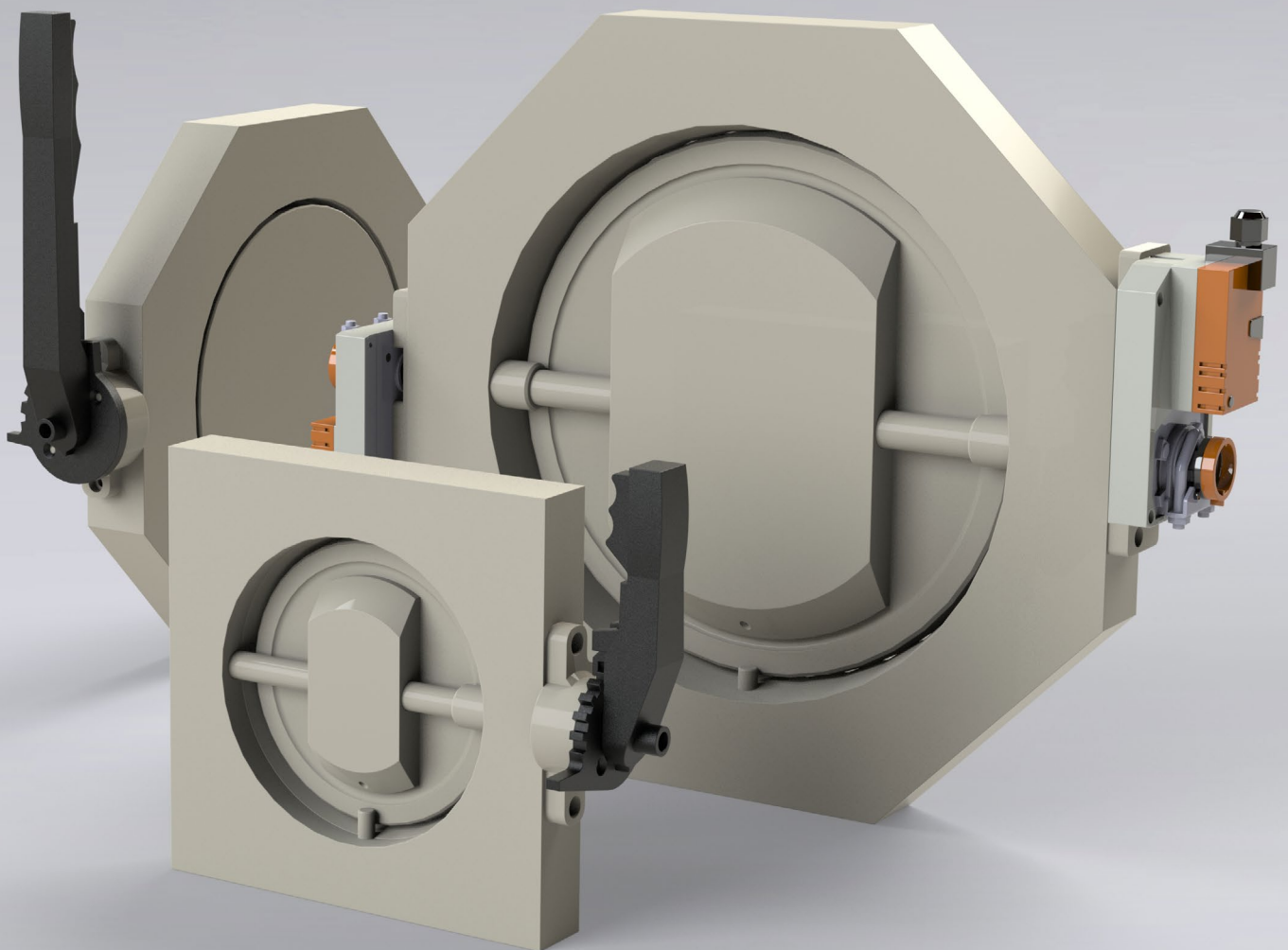

The measure for chemically aggressive exhaust air and gases. Worldwide.



The gas-tight butterfly valves in plastic from Colasit ensure safe handling of aggressive, gaseous media. They feature a special sealing system, are available in an ATEX-compliant version for potentially explosive atmospheres and fulfil the leak test in accordance with DIN EN 12266-1. The medium flowing through has no contact with metal parts.

### Construction

- One-piece fitting body, solid
- Eccentrically mounted flap disc
- no metal parts in the media flow

### Sealing

- Shaft/housing: O-ring
- Flap disc/housing: Thermoplastic sealing lip / spring element

### Areas of application

- Pharmaceutical packaging systems, isolators for pharmaceutical applications, cleanroom technology, disinfection airlocks - e.g. for applications with H<sub>2</sub>O<sub>2</sub> (hydrogen peroxide) as a disinfectant
- Exhaust gas cleaning systems, biofilters, flue gas cleaning
- Service flaps for standby fans
- Laboratory, animal rooms
- Process technology
- Waste water purification systems
- Refrigeration systems

### Installation

- Intermediate flange type, installation with horizontal shaft
- optionally with flange sockets or welded-on pipe sockets

### Actuation / actuators

- Hand lever
- Worm gearbox
- Electric or pneumatic drives

### Technical data

- Operating pressure standard +/- 5000 Pa
- Operating temperatures up to 90 °C (depending on material)

### Construction materials

- Housing  
**PP, PPS-el, PE, PE-el, PVC, PVDF**
- Flap disc  
**PP, PPS-el, PE-el, PVC, PVDF**
- Shaft seals  
**EPDM, FKM, FEP, CR, NBR**
- Spring element  
**EPDM, FKM**

### Ex protection

- available in ATEX versions for **Zone 1 / 2**  according to II2D Ex h IIC 135 °C Db or II2G Ex h IIC T4 for gas and dust

### Connection flange standards

- Standard: Colasit standard, Beck standard, DIN 24154 (ventilation)
- Optional: DIN, VSM ASA, BS, etc. (Process)

### Accessories

- Connecting flanges, connecting collar rings
- ISO mounting support for drives or gearboxes
- Limit switch/proximity switch, also for manually operated flaps
- Throttles for setting the opening and closing speed
- Control valves, positioners

**Flange pattern, housing contour**

- All flange standards are possible, the housing external dimensions may vary
- Special sizes on request

**Main features**

- in plastic for corrosive gaseous media
- tested, gas-tight version
- available for ATEX zone 1 + 2
- various drive types

The gas-tight butterfly valves from Colasit are available in the following versions:

DN	Pipe Ø d	Housing A x A	Installation length L	H	Weight with hand lever kg	Weight with Gearbox kg
50	63	140 x 140	50	*	1	
80	90	165 x 165	40	*	2	
100	110	185 x 185	40	*	2	
100	125	200 x 200	40	*	2	
125	140	215 x 215	40	*	2	
150	160	235 x 235	40	*	3	
175	180	255 x 255	40	*	3	
200	200	275 x 275	40	*	3	
225	225	305 x 305	50	*	4	
250	250	330 x 330	50	*	5	
275	280	360 x 360	50	*	6	
300	315	400 x 400	50	*	7	
350	355	465 x 465	60	*	11	
400	400	520 x 520	60	*	16	20
450	450	585 x 585	60	*	24	27
500	500	640 x 640	80	*	31	34
500	560	720 x 720	80	*		42
600	630	800 x 800	80	*		55
700	710	900 x 900	100	*		71
800	800	990 x 990	100	*		95
900	900	1100 x 1100	120	*		129
1000	1000	1200 x 1200	120	*		150
1200	1250	1480 x 1480	150	*		286
1500	1500	1780 x 1780	150	*		320

\* depending on drive type

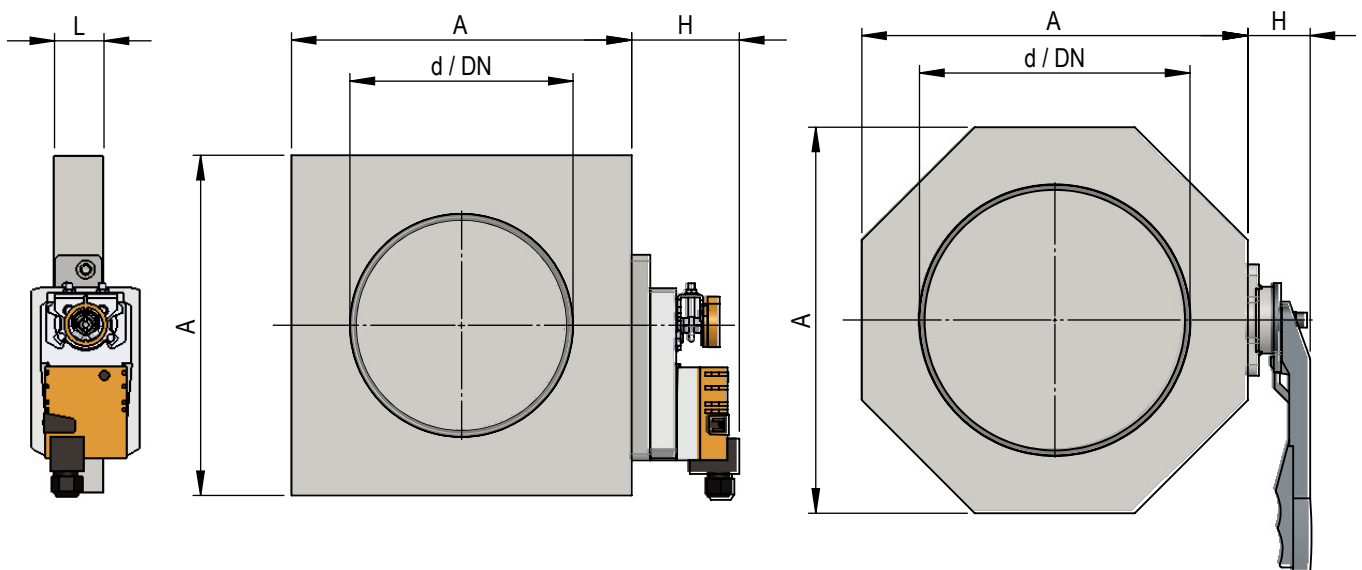

**Design 1**  
DN50 - DN200

**Design 2**  
DN225 - DN1500

# Worldwide

Colasit is a worldwide leading provider of chemically resistant fans, exhaust air purification systems, ventilation systems for corrosive and environmentally harmful exhaust air and gases as well as apparatus and processing systems for chemically aggressive liquid media.



Exhaust air purification systems made of plastic for treating environmentally hazardous exhaust air and gases



Plastic fans for efficient and safe conveying of corrosive exhaust air and gases



Ventilation systems made of plastic for efficient routing of corrosive exhaust air and gases



Processing systems, containers, vessels, and equipment for safe handling of chemically aggressive liquid media



Installation, repair, and replacement parts services

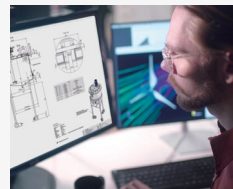

Consultation and engineering services in plastic construction for individual components to entire systems

**COLASIT Holland B.V.**  
Plastic construction • Larenweg 56 • 5234 KC 's-Hertogenbosch, The Netherlands  
Phone +31 (0)73 641 83 15 • [verkoop@colasit.nl](mailto:verkoop@colasit.nl)  
[www.colasit.nl](http://www.colasit.nl)



**Competence in plastics. Worldwide.**